

ADJUST THE ARC AND RADIUS OF ANY SPRINKLERS IN THIS AREA TO AVOID SPRAYING THE TEMPORARY SALES OFFICE WHILE IT IS LOCATED IN THE IRRIGATED AREA.

FIELD LOCATE DRAINAGE CONDUIT FOR SLEEVE.

S.R.707

TRACOASTAL WATERWAY

ATLANTIC OCEAN

CREATED FOR INFORMATION ONLY
12.23.92

DRC 92

ur0334.igr
JUPITER NORTH 10/40/43 PG4

SHEET
4
OF 6

IRRIGATION PLAN

OWNER:
OTTO B DIVOSTA AND BETTY J. DIVOSTA PARTNERSHIP
4500 P.C.A. BLVD., SUITE 400
PALM BEACH GARDENS, FLORIDA 33418
407-627-2112

DEVELOPER:
R. NASON SIMPSON
SANDCLIFFE DEVELOPMENT COMPANY
25 SADDLEBACK ROAD
ORQUESTA, FLORIDA 33469
407-744-2000

PLANNER/LANDSCAPE ARCHITECT:
JOHN R. AREND
THE EVANS GROUP
1000 NORTH ORANGE AVE., SUITE 200
ORLANDO, FLORIDA 32801
407-849-6310

ENGINEER:
MICHAEL B. SCHORAH P.E.
MICHAEL B. SCHORAH & ASSOCIATES, INC.
1950 FOREST HILL BLVD.
WEST PALM BEACH, FLORIDA 33406
407-968-0080

ENVIROSCAPE LAND PLANNING & LANDSCAPE ARCHITECTURE
A DIVISION OF THE EVANS GROUP

1000 N. ORANGE AVE., SUITE 200
ORLANDO, FLORIDA 32801
321-849-8300
FAX 407-649-3000

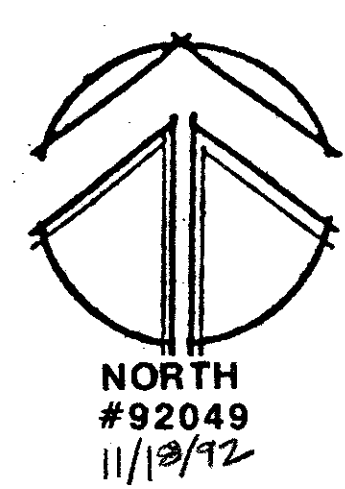
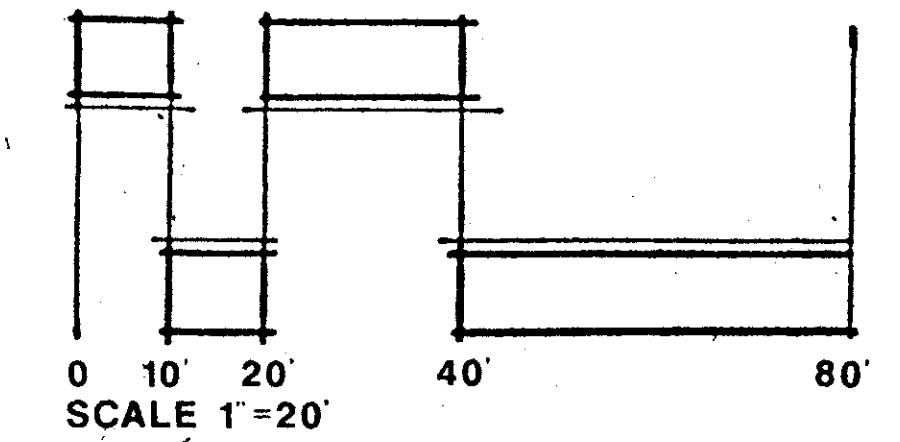

Jupiter North Subdivision - Irrigation Plan